

SAN ANTONIO WATER SYSTEM PURCHASING DEPARTMENT

Issued By: **D. Anthony Rubin**
BID NO.: 18-18090

Date Issued: July 9, 2018

FORMAL INVITATION FOR BIDS
EARLY PROCUREMENT OF ON-SITE SODIUM HYPOCHLORITE GENERATION SYSTEM
FOR THE CENTRAL WATER INTEGRATION PIPELINE PROJECT
ADDENDUM 1

Sealed bids addressed to the Purchasing Director, San Antonio Water System, 2800 US Hwy 281 North, Administration Bldg., 5th Floor, San Antonio, TX 78212 will be received until **3:00 p.m. July 13, 2018** and then publicly opened and read aloud for furnishing materials or services as described herein below,

The San Antonio Water System Purchasing Department is willing to assist any bidder(s) in the interpretation of bid provisions or explanation of how bid forms are to be completed. Assistance may be received by visiting the Purchasing Office in the SAWS Main Office, 2800 US Hwy 281 North, San Antonio, TX 78212, or by calling (210) 233-3819.

This invitation includes the following:

Invitation for Bids
Terms and Conditions of Invitation for Bids

Specifications and General Requirements
Price Schedule

The undersigned, by his/her signature, represents that he/she is authorized to bind the Bidder to fully comply with the Specifications and General Requirements for the amount(s) shown on the accompanying bid sheet(s). By signing below, Bidder has read the entire document and agreed to the terms therein.

Signer's Name: _____ Firm Name: _____
(Please Print or Type)

Address: _____

Signature of Person Authorized to Sign Bid _____ City, State, Zip Code: _____

Email Address: _____ Telephone No.: _____

Fax No.: _____

Payment Terms are Net 30.

Please check the following blanks which apply to your company:

Ownership of firm (51% or more):

Non-minority Hispanic African-American Other Minority (specify) _____

Female Owned Handicapped Owned Small Business (less than \$1 million annual receipts or 100 employees)

Indicate Status: Partnership Corporation Sole Proprietorship Other (specify) _____

Tax Identification Number: _____

To report suspected ethics violations impacting the San Antonio Water System, please call 1-800-687-1918.

This **Addendum 1** is issued to answer the following questions and issue changes to the bid sent to you on June 22, 2018. All other terms and conditions of the original bid document remain unchanged.

REVISIONS TO CONTRACT DOCUMENTS AND TECHNICAL SPECIFICATIONS

SECTION 11366 – ON-SITE SODIUM HYPOCHLORITE GENERATION SYSTEM

- a) Part 2.13, C., delete “See Specification Section 17515, Instrumentation and Controls – Communications Interface Equipment” and REPLACE with “See Specification Section 17306 – Vendor Packaged Process Control Systems.”

REVISIONS TO DRAWINGS

SHEET I-1006 – TYPICAL PRESSURE FILTER P&ID

- a) Delete sheet I-1009 in its entirety and replace with new I-1009 provided.
- b) Delete sheet I-1010 in its entirety and replace with new I-1010 provided.



Pre-Purchase of On-Site Sodium Hypochlorite Generation
System for the
Central Water Integration Pipeline Project

SAWS Job No. 18-8616
Solicitation No. 18-18090

ADDENDUM NO. 1
JULY 2018



Tetra Tech, Inc.
Texas Registered Engineering Firm No. 3924
700 North Saint Mary's Street, Suite 300
San Antonio, Texas 78205

7/9/2018 1:24:22 PM - C:\PROJECTS\ORLANDO\OR09308200-09308-18001-B\CAD\SHETS\TREATMENT_FACILITY\1-1009_1010.OSG FACILITY P&ID.DWG - WASON, BANKS

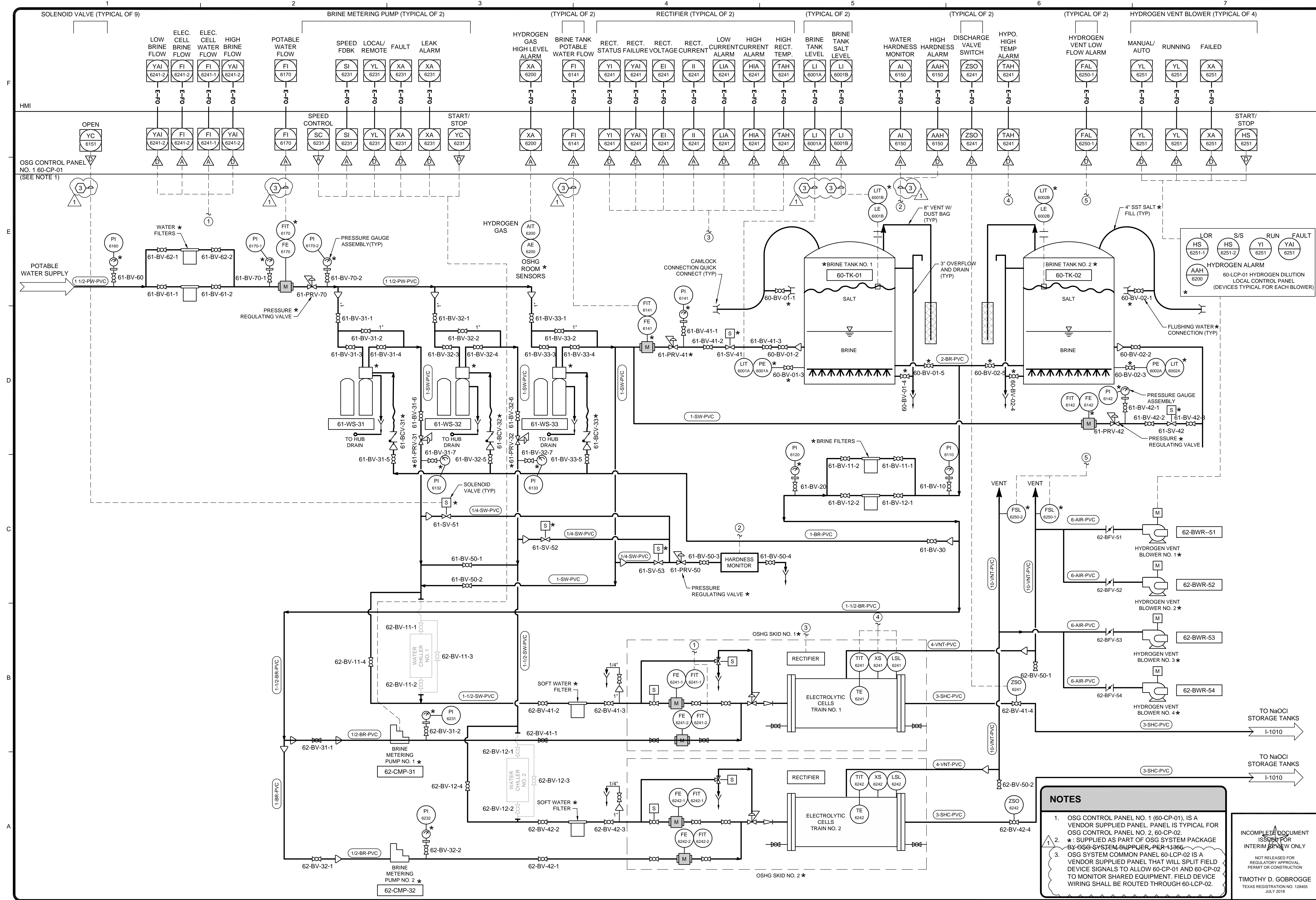

NOTES

- OSG CONTROL PANEL NO. 1 (60-CP-01), IS A VENDOR SUPPLIED PANEL. PANEL IS TYPICAL FOR OSG CONTROL PANEL NO. 2, 60-CP-02.
- * : SUPPLIED AS PART OF OSG SYSTEM PACKAGE BY OSG SYSTEM SUPPLIER, PER 1366.
- OSG SYSTEM COMMON PANEL 60-LCP-02 IS A VENDOR SUPPLIED PANEL THAT WILL SPLIT FIELD DEVICE SIGNALS TO ALLOW 60-CP-01 AND 60-CP-02 TO MONITOR SHARED EQUIPMENT. FIELD DEVICE WIRING SHALL BE Routed THROUGH 60-LCP-02.

INCOMPLETE DOCUMENT
ISSUED FOR
INTERIM REVIEW ONLY

NOT RELEASED FOR
REGULATORY APPROVAL,
PERMIT OR CONSTRUCTION

TIMOTHY D. GOBORGGE
TEXAS REGISTRATION NO. 128455
JULY 2018

TETRA TECH
Texas Registration No. F-3924

www.tetrattech.com
700 N. St. Mary's, Suite 300
San Antonio, TX 78205
Ph (210) 298-7900 Fax (210) 226-8497

EP-2 BID SET

SAN ANTONIO WATER SYSTEM

OSG FACILITY
P&ID - 1

MARK	DATE	DESCRIPTION
1	7/9/2018	ADDENDUM NO. 1

BY: _____

PROJECT: 200-09308-18001
DESN: BRW
DRWN: JTE
CHKD: TG

I-1009

Bar measures 1 inch, otherwise drawing is not to scale

7/9/2018 1:45:21 PM - C:\PROJECTS\ORLANDO\ORLANDO\09308\200-09308-18001-BC\AD\SSHEETS\TREATMENT_FACILITY\I-1010_OSG_FACILITY_P&ID.DWG - WASON, BANKS

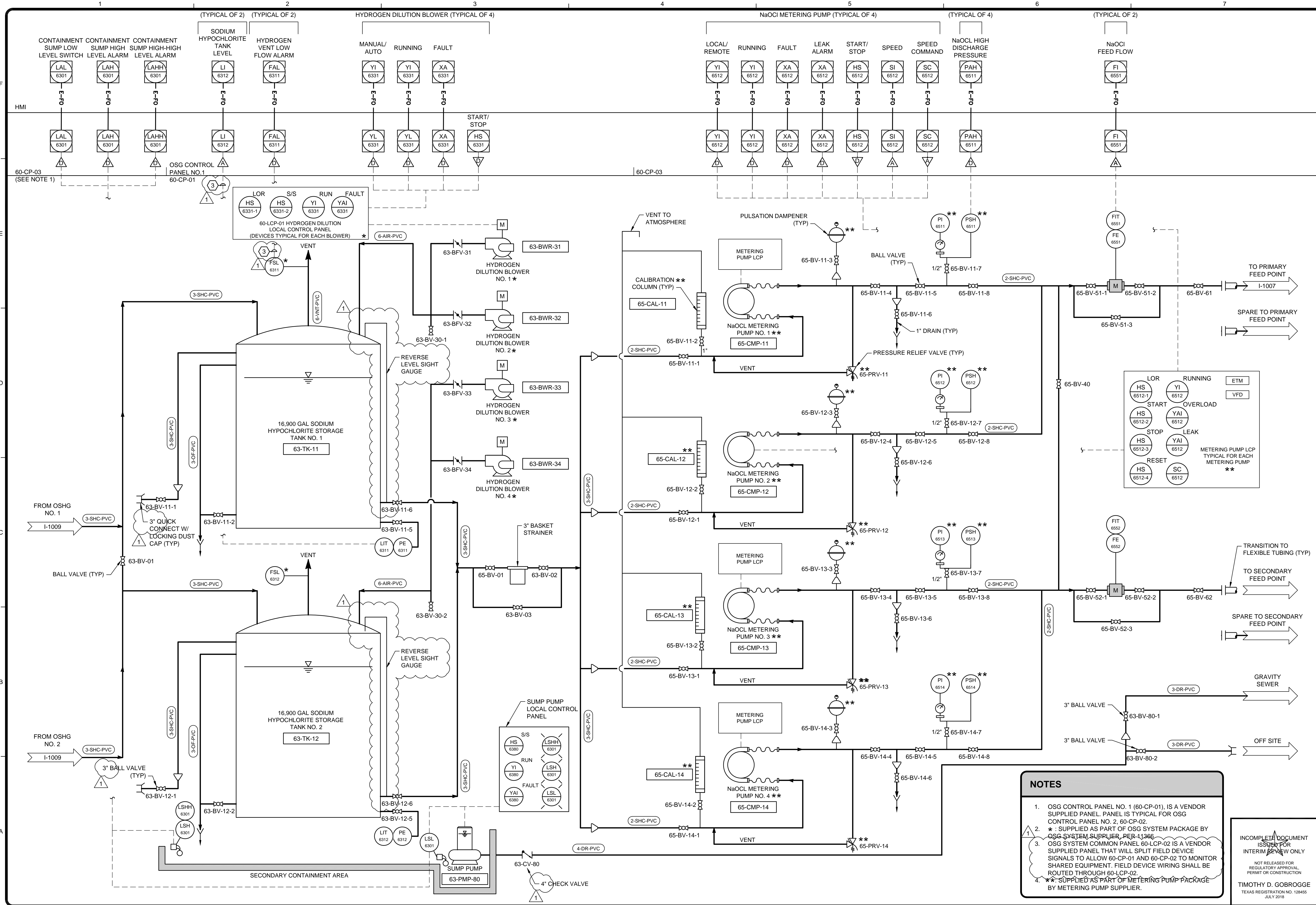

NOTES

- OSG CONTROL PANEL NO. 1 (60-CP-01), IS A VENDOR SUPPLIED PANEL. PANEL IS TYPICAL FOR OSG CONTROL PANEL NO. 2, 60-CP-02.
- * : SUPPLIED AS PART OF OSG SYSTEM PACKAGE BY OSG SYSTEM SUPPLIER, PER 11366.
- OSG SYSTEM COMMON PANEL 60-LCP-02 IS A VENDOR SUPPLIED PANEL THAT WILL SPLIT FIELD DEVICE SIGNALS TO ALLOW 60-CP-01 AND 60-CP-02 TO MONITOR SHARED EQUIPMENT. FIELD DEVICE WIRING SHALL BE ROUTED THROUGH 60-LCP-02.
- ** : SUPPLIED AS PART OF METERING PUMP PACKAGE BY METERING PUMP SUPPLIER.

INCOMPLETE DOCUMENT
ISSUED FOR
INTERIM REVIEW ONLY

NOT RELEASED FOR
REGULATORY APPROVAL
PERMIT OR CONSTRUCTION

TIMOTHY D. GOBROGGE
TEXAS REGISTRATION NO. 129455
JULY 2018

<p>TETRA TECH Texas Registration No. F-3924 www.tetra-tech.com 700 N. St. Mary's, Suite 300 San Antonio, TX 78205 Ph (210) 299-7900 Fax (210) 226-5497</p>	
EP-2 BID SET	
<p>SAN ANTONIO WATER SYSTEM</p>	
BY	
DATE	
DESCRIPTION	
MARK	
1	7/9/2018 ADDENDUM NO. 1
SAN ANTONIO WATER SYSTEM CENTRAL WATER INTEGRATION PIPELINE PROJECT TERMINUS FACILITY OSG FACILITY P&ID - II	
PROJ:	200-09308-18001
DESIGN:	BRW
DRWN:	JTE
CHKD:	TG
I-1010	